

Comparison of Different Panel
 各型地板材料性能比较表

Performance性能		“钢质水泥基地板 Steel cement panel”	钢质空心地板 Steel hollow panel	木质基地板 Woodcore panel	硫酸钙基地板 Calcium Sulphate panel	压铸铝地板 Die-casting aluminum panel
Ultimate load极限荷载		A	B	C	D	E
Safety factor安全系数		A	B	C	D	E
Overload protection超载保护		A	B	C	D	E
Fire rating防火性能		A	B	E	A	E
Panel size地板尺寸精确度		B	B	B	B	A
Panel weight(bare finish)裸板重量		C	A	A	E	A
Bare panel sound insulation裸板隔音性能		C	C	B	A	E
Walking feeling步行感		A	B	A	A	B
Recycled content回收性原材料比例		B	B	D	A	E
Support for Green building certificate 绿色建筑申请支持		B	B	D	A	E
Cost efficiency估计单位成本		A	D	D	B	E
Cutting ease and cost切割难度和切割成本		B	A	A	E	C
Application 用途	Office办公区	A	B	A	A	E
	Data center数据中心	A	B	D	B	B
	Education教育区	A	D	A	B	E
	Casino赌场	A	E	D	A	B
	Industrial cleanroom洁净厂房	B	E	E	E	A
	Library图书馆	A	C	B	A	E

Note备注:

- (1) ZTFLOOR has continuous product and product data improvement. It reserves the right to change type design and specifications without notice.
 中天机房公司致力于产品和技术的不断更新。我们保留对产品品种设计和性能的修改且恕不另行通知的权利。
- (2) 'A' ----Most advantage最优, 'E' ----Least advantage最差。
- (3) The comparison is based on the panels of the same concentrated loading grade. 此对照表基于各品种同等集中荷载的地板。

常州市武进中天机房设备有限公司

CHANGZHOU WUJIN ZHONGTIAN COMPUTER-ROOM EQUIPMENT CO.,LTD

地址:江苏常州市武进区横林镇卫星工业园 邮政编码:213103
 Address: Weixing Industrial Zone, Henglin Town, 213103 Changzhou City, Jiangsu Province, P.R. of China

电话(Tel): +86-519-88501738
 传真(Fax): +86-519-88503251
 http://www.ztfloor.com
 E-mail: sun@ztfloor.com

- ZTFLOOR passes third-part Green Material certificate. Please ask for details through company sales.
 中天公司已通过第三方绿色环保建材认证, 请向公司业务经理索取相关资料。
- For more new products, please contact ZTFLOOR sales.
 更多新产品, 请咨询中天公司业务经理。

http://www.ztfloor.com

朝晖® ZTFLOOR®

ACCESS FLOOR SYSTEM

高架活动地板(2015版)



常州市武进中天机房设备有限公司

CHANGZHOU WUJIN ZHONGTIAN COMPUTER-ROOM EQUIPMENT CO.,LTD



COMPANY PROFILE

公司简介

As one of the largest access floor manufacturers and exporters in China, in 2013, ZT Floor has supplied over 2 million square meters of access floor in commercial office buildings, data centers, educational facilities, the casinos, clean rooms and libraries.

The company is expanding, with plant area over 60,000 square meters and 200 workers. The main products include access floor system, data center products, underfloor air conditioning and underfloor wiring.

ZT Floor leverages its 26 years of experience in the industry to provide support to customers by its high efficiency, energy conservation, intelligence and green spaces products.

常州市武进中天机房设备有限公司成立于1988年，现有员工200人，工厂面积约6万平方米。公司主营高架活动地板系统产品的设计、生产、销售和施工。产品系列涵盖架空活动地板，数据中心产品，地板送风空调系统和地板电器电缆产品四大系统。公司积极打造产品和服务平台，以提升客户价值为信念，为全球活动地板用户创造高效、节能、智能、绿色空间提供整体解决方案。作为国内最大的活动地板系统产品供应商和出口商之一，公司每年出库约200万平方米活动地板材料和系统产品，产品用途包括办公楼、数据中心、教育区、赌场、洁净厂房和图书馆等。



Impact Load Test
冲击测试



Rolling Load Test
滚动载荷测试



Hardness Test
硬度测试



Salt-spray Test
盐雾测试



Coating Thickness Test
喷粉厚度测试



Flatness Test
平整度测试



Concentrated Load Test
集中载荷测试



Design Load Test
设计压力载荷测试

CERTIFICATES

认证证书

For more certificates, please contact us.
请向中天公司索取更详细公司或产品证书。



质量控制

QUALITY CONTROL

STEEL CEMENTITIOUS PANEL

全钢高架活动地板



ZT50 OA PANEL ZT50 OA 地板



Structure

ZT50 OA panel is made of steel plate, top to be SPCC material, bottom to be ST14 material, after pan formed and joined together by resistance welding, the panel is coated with epoxy paint, then infilled with light cement.

ZT50 OA地板采用SPCC硬质冷轧板，底部采用ST14拉伸板，经拉伸、点焊、磷化、喷塑后，内腔填充轻质发泡水泥而成，四角带有角锁孔。

Size

500mm×500mm

Feature

- All-steel structure, nice loading capacity
- Excellent fire resistance ability
- Good dimension accuracy, panel can be interchangeable
- 全钢结构，地板承重能力好
- 良好的防火性能
- 地板尺寸精度高，互换性好，易安装，维修方便

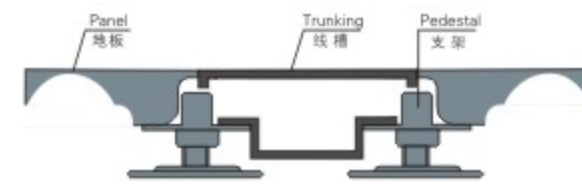
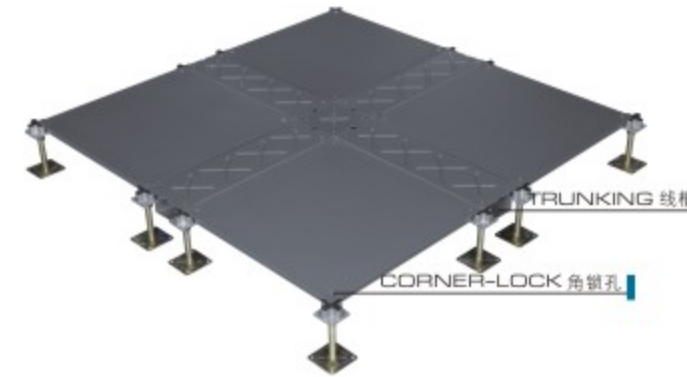
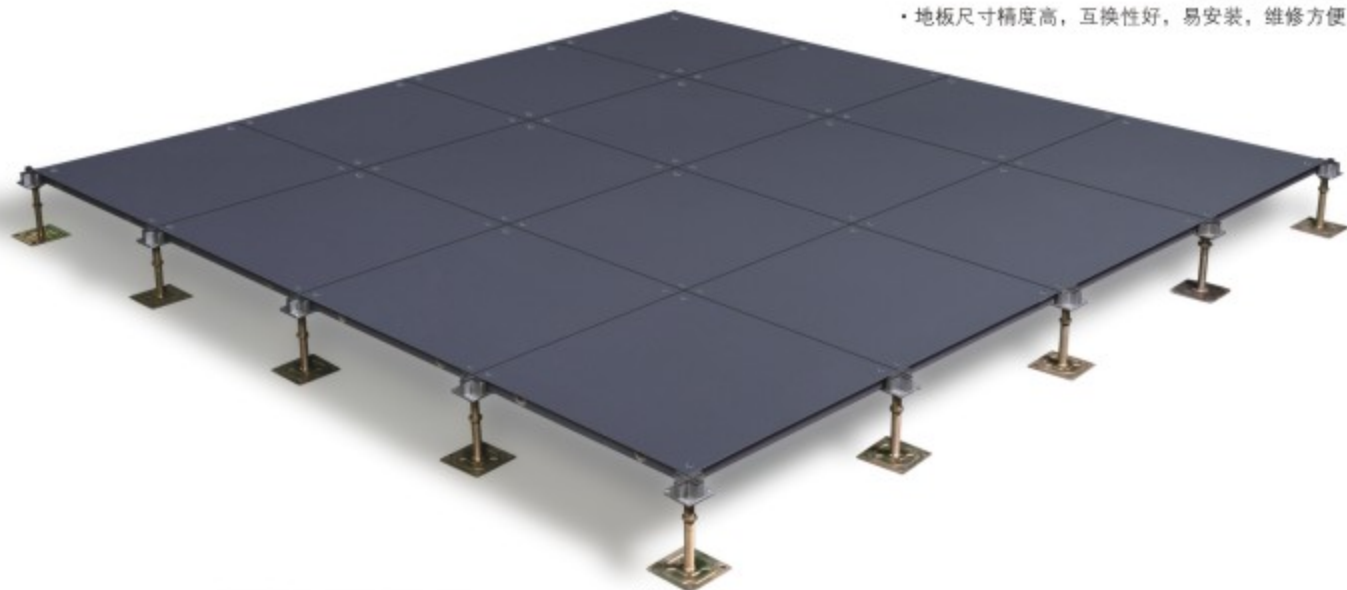

线槽地板安装示意图

ZT50-A-C5 PANEL

Wire Trunking System

A workstation can be easily and quickly relocated with cable management without disruption. Convenient for connecting wire at any point without cutting floor. Suitable for all kinds of plug socket terminals. Adjustable wire-connected location.

线槽地板可根据使用要求任意添加线槽，布线更具灵活性，可以将强弱电分开隔离。便于检修、节约大楼空间，突出智能化，电板的功能性。



ZT50E



ZT50E



ZT50-C2E



ZT50-C2E

Type 型号	Size 尺寸	Concentrated 集中载荷	Impact Load 冲击载荷	Ultimate Load 极限载荷	Uniform Load 均布载荷	Rolling Load 滚动载荷N	Remarks 备注
International	国内型号	mm	N	N	N	NM ²	10次 10000次
OA668	HDG500 28QG	500 × 500 × 28	≥2990	670	≥8890	≥12500	2215 1548
OA800	HDG500 28QG	500 × 500 × 28	≥3596	670	≥10799	≥19796	2959 2215
OA1000	HDG500 28BG	500 × 500 × 28	≥4498	670	≥13494	≥23294	3596 2959

OA 智能化
楼宇架空标
准活动地板
(CISCA)

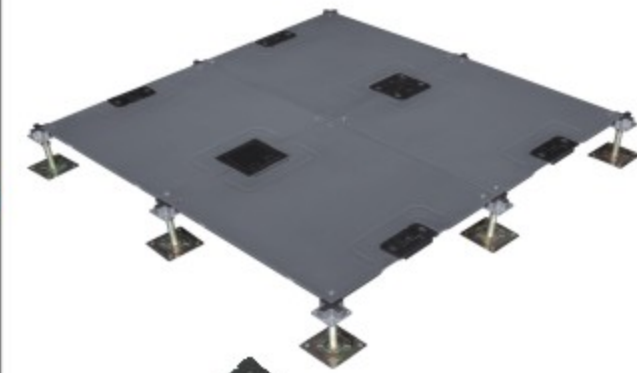

ZT50-C2 PANEL

Feature

OA access floor system effectively reduces energy cost and improves inside air quality, makes it to be green office environment.

OA地板系统能有效的节能，提高室内空气质量，创造绿色办公环境。

STEEL CEMENTITIOUS PANEL

全钢高架活动地板



ZT50-B PANEL ZT50-B型扣槽网络地板



Structure

ZT50-B panel is elevated innovation and breakthrough, comparing with traditional access floor system. The new ZT50-B series has the same advantage of ZT50 panel, but more convenient, environmental protected. Now it is widely used in Japan, Qatar, Bahrain, Korea and other countries.

ZT50-B型扣槽网络地板是对传统网络地板的突破及创新。除具有普通ZT50地板的优点之外，它使用范围更广，安装更方便，更环保。目前在日本、卡塔尔、巴林、韩国被广泛应用。

Size

500×500×25mm

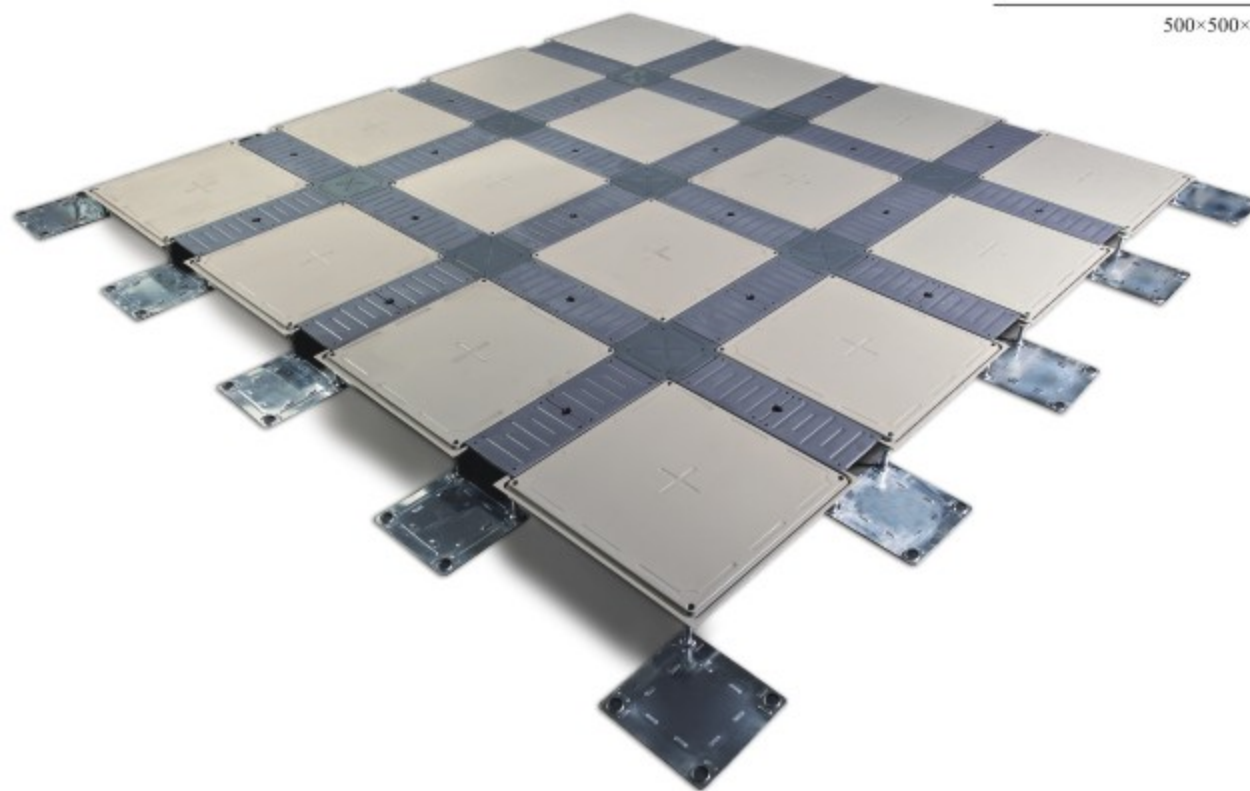

Product Description

ZT50-B panel is supported by 4 pedestals and flank cap and central cap.
ZT50-B扣槽地板由支架和盖板组成。

Feature

- Environmental protected, economical and recyclable.
- Light weight, 1/2 to 2/3 of common access floor.
- Good conductivity and air leakage, flexible trunks for wires and cables.
- Specially designed for low finished flooring height
- 绿色环保，回收性能好
- 重量轻，只有普通地板的1/2到2/3
- 导电性能和透气性较好，便于布线
- 特别为低完成高度设计

Center Cap 中间盖板

Flank Cap 边盖板

Trunking 线槽

Outlet box 地插座

Base Connector 连接基座

Screw Fedestal 螺丝支架

Trunking

Trunking for wires is one of the advantages of ZT trunking floor. Cover flank covers on basic panel edges after lying wires in trunks. Each panel stands separately, making it very convenient to lie flank cover before or after wires.

地板线槽系统: 此系统为产品的重要功能之一，此功能能达到现有的任何一款其它网络地板系统无法达到的效果。前述线槽安装自然成型后，可先将盖板安装，或布线完成后再安装盖板。由于每块地板为独立支撑，故先布线或后布线都很方便与安全。



Type 型号	Size 尺寸	Concentrated 集中载荷	Impact Load 冲击载荷	Ultimate Load 极限载荷	Uniform Load 均布载荷	Rolling Load 滚动载荷N	Remarks 备注	
International	国内型号	mm	N	N	N	NM ²	10次 10000次	
OA668	HDG500 25QG	500×500×25	≥2990	670	≥8890	≥12500	2215 1548	OA 智能化 楼宇架空 标准活动地板 (CISCA)
OA800	HDG500 25QG	500×500×25	≥3596	670	≥10799	≥19796	2959 2215	
OA1000	HDG500 25BG	500×500×25	≥4498	670	≥13494	≥23294	3596 2959	

STEEL CEMENTITIOUS PANEL

全钢高架活动地板



ZT60 OA PANEL ZT60 OA地板



Structure

ZT60 OA panel is made of steel plate, top to be SPCC material, bottom to be ST14 material, after pan formed and joined together by resistance welding, the panel is coated with epoxy paint, then infilled with light cement.

ZT60 OA地板由冷轧钢板和拉伸钢板构成，板内填充轻质发泡纯水泥。用宝钢钢板经拉伸、点焊、磷化、喷塑做成，内腔填充发泡水泥，带有角锁孔。

Size

600×600×35mm

Feature

Embossment structural. Enhance the concentrated load capability.
凸点设计，增强集中载荷

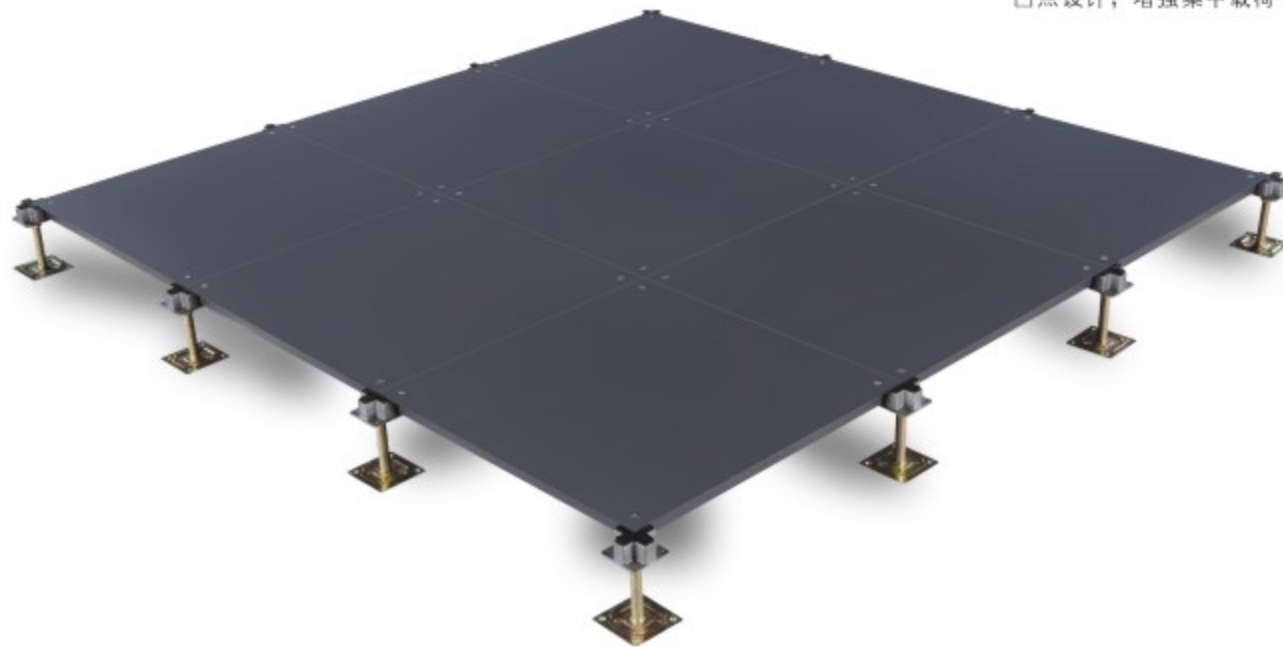

SPCC steel SPCC冷轧硬板

Light cement 发泡水泥

ST14 steel ST14拉伸钢板

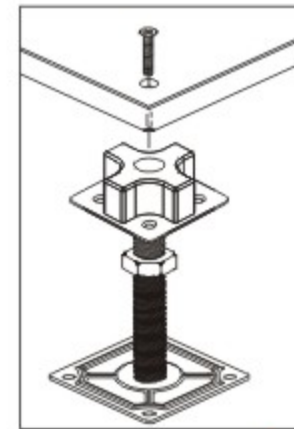
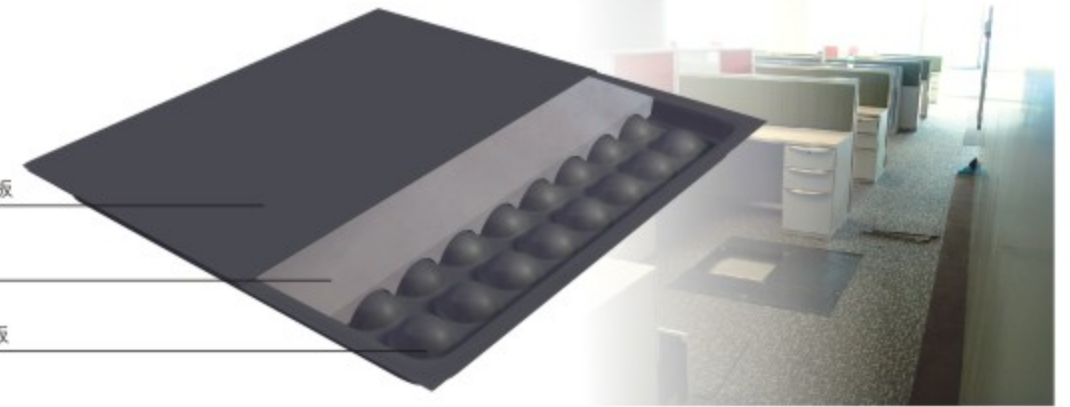

CORNER LOCK SYSTEM

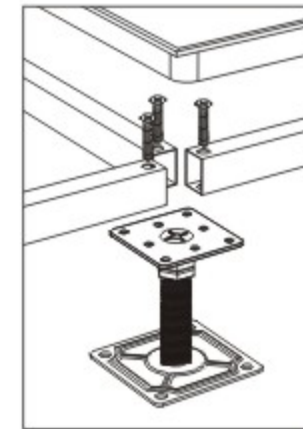

BOLT-ON STRINGER SYSTEM

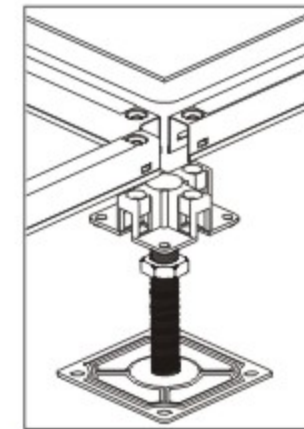

SNAP-ON STRINGER SYSTEM

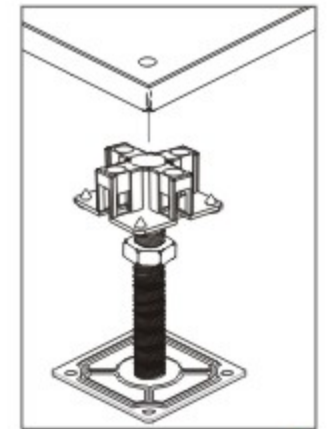

FREE STANDING SYSTEM

Structure

- Screw down design supports the system effectively and makes the installation easily and stable.
- The load is transferred directly onto the center of pedestal column.
- Different types of understructures are available for install OA panel system.

- 角锁孔连接使地板安装更稳固，更好地支撑地板系统。
- 地板承载力通过角铝支架均匀分散。
- 有不同种类支架系统可供选择安装OA地板。



Type	Size	Concentrated	Impact Load	Ultimate Load	Uniform Load	Rolling Load	Remarks
型号	尺寸	集中载荷	冲击载荷	极限载荷	均布载荷	滚动载荷N	备注
International	mm	N	N	N	N/M ²	10次 10000次	
SC668	HDG600 35QG 600×600×35	≈2990	670	≈8890	≈12500	2215 1548	OA 智能化 楼宇架空标 准活动地板 (CISCA)
SC800	HDG600 30QG 600×600×30	≈3596	670	≈10799	≈19796	2959 2215	
	HDG610 35BG 610×610×35						
SC1000	HDG600 35ZG 600×600×35	≈4498	670	≈13494	≈23294	3596 2959	
	HDG610 35ZG 610×610×35						
SC1250	HDG600 35ZG 600×600×35	≈5595	670	≈16797	≈33084	4498 3596	
	HDG610 35ZG 610×610×35						
SC1500	HDG600 35ZG 600×600×35	≈6693	670	≈20090	≈42581	5595 4498	
	HDG610 35ZG 610×610×35						
SC2000	HDG600 35ZG 600×600×35	≈8898	670	≈26685	≈49784	6693 5595	
	HDG610 35ZG 610×610×35						
SC2500	HDG600 35ZG 600×600×35	≈11093	670	≈33290	≈58280	8898 6693	
	HDG610 35ZG 610×610×35						

STEEL CEMENTITIOUS PANEL

全钢高架活动地板

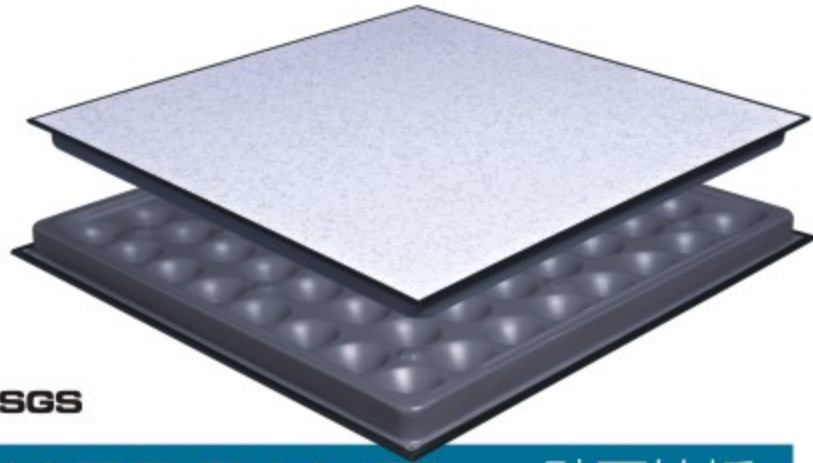

LAMINATE PANEL 贴面地板



Feature

- Used for computer room, data center and communication center
- Excellent rolling load & ultimate load performance
- Light weight cement makes panels solid and quiet
- Black/grey epoxy paint finish for long time protection
- Class A flame spread and smoke development rating
- Convenient installation supplies an excellent solution for office integrity, wiring and data cable service
- 适用于计算机房、数据中心、通讯中心
 - 滚动载荷与极限载荷强
 - 轻质水泥填充
 - 黑/灰色喷塑美观且使用寿命长
 - 防火A级
- 便于安装、布线，维护机房整体性



Wide range finishes available 贴面材料

- High Pressure Laminate
- Conductive vinyl tile
 - Ceramic
 - Carpet tile
 - Linoleum
- Granite/Marble
 - 防火板
 - 导电PVC
 - 瓷砖
 - 地毯
 - 亚麻地材
 - 花岗岩/大理石

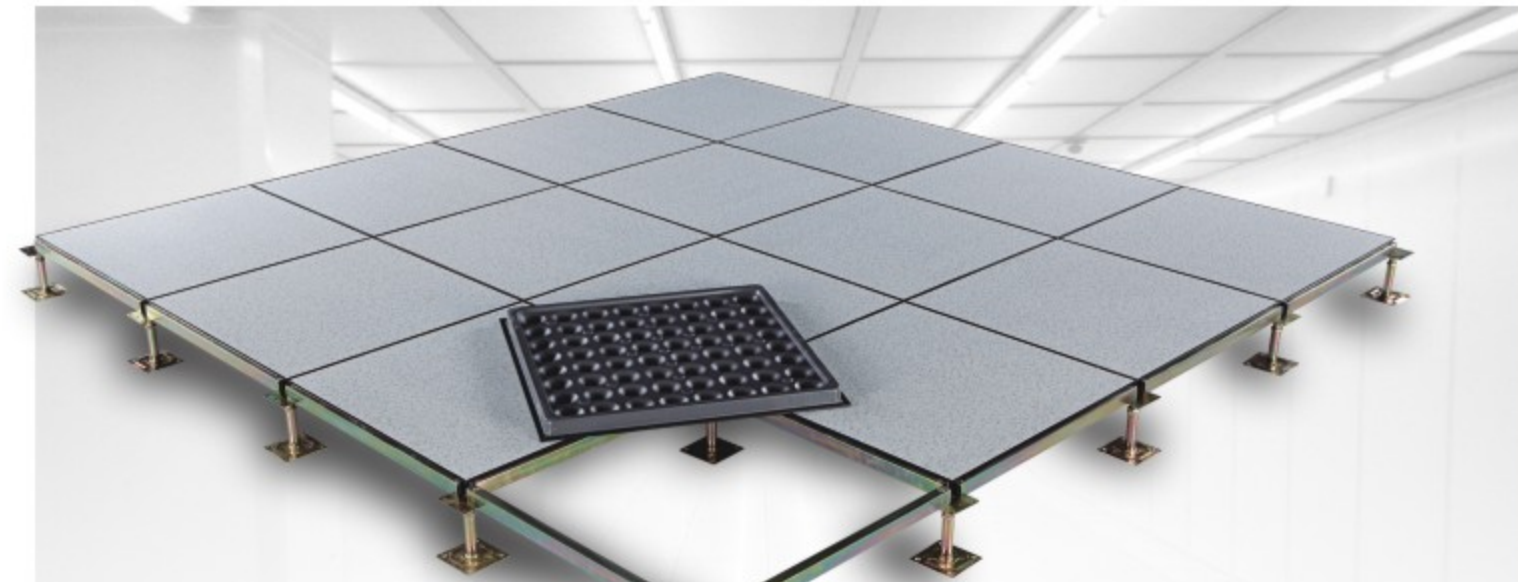

Control center 控制中心



Communication center 通讯中心

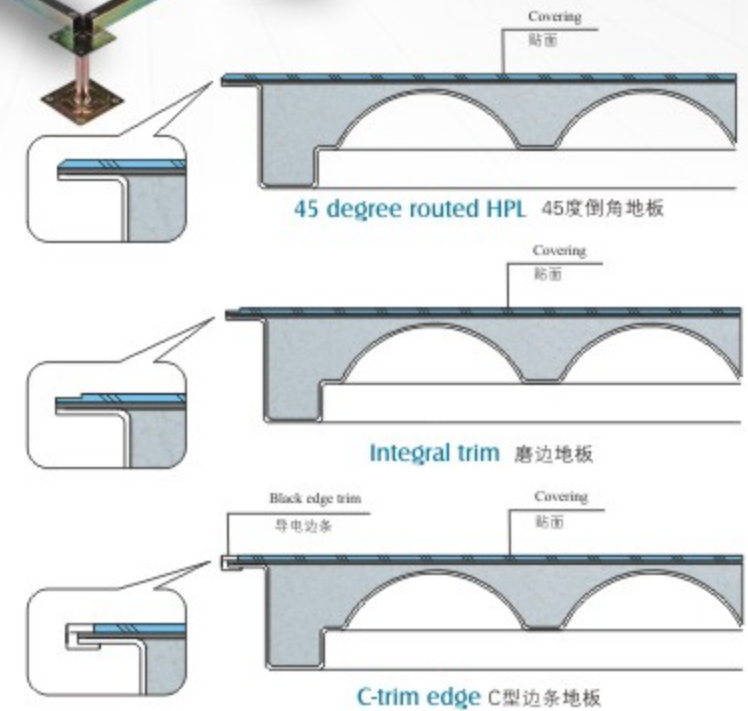

Type 型号	Size 尺寸	Concentrated 集中载荷	Impact Load 冲击载荷	Ultimate Load 极限载荷	Uniform Load 均布载荷	Rolling Load 滚动载荷N	Remarks 备注	
International	国内型号	mm	N	N	N	N/M ²	10次 10000次	
SC668	HDG600 35QG	600 × 600 × 35	≥ 2990	670	≥ 8890	≥ 12500	2215 1548	Floor system resistance 1 × 10 ⁹ - 1 × 10 ¹⁰ Ω (系统电阻) 可提供进口或国产的多种色彩与花纹的防静电面材安装板高度 ≥ 60mm
SC800	HDG600 30QG	600 × 600 × 30	≥ 3596	670	≥ 10799	≥ 19796	2959 2215	
	HDG600 35BG	600 × 600 × 35						
SC1000	HDG610 35BG	610 × 610 × 35	≥ 4498	670	≥ 13494	≥ 23294	3596 2959	
	HDG600 35ZG	600 × 600 × 35						
SC1250	HDG610 35ZG	610 × 610 × 35	≥ 5595	670	≥ 16797	≥ 33084	4498 3596	
	HDG600 35ZG	600 × 600 × 35						
SC1500	HDG600 35ZG	600 × 600 × 35	≥ 6693	670	≥ 20090	≥ 42581	5595 4498	
	HDG610 35ZG	610 × 610 × 35						
SC2000	HDG600 35ZG	600 × 600 × 35	≥ 8898	670	≥ 26685	≥ 49784	6693 5595	
	HDG610 35ZG	610 × 610 × 35						
SC2500	HDG600 35ZG	600 × 600 × 35	≥ 11093	670	≥ 33290	≥ 58280	8898 6693	
	HDG610 35ZG	610 × 610 × 35						

WOODCORE ACCESS FLOOR 木质高架活动地板

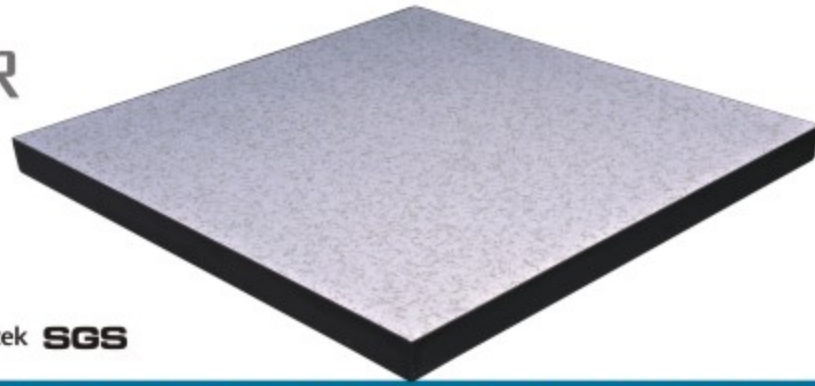

PVC SEALED PANEL PVC封边

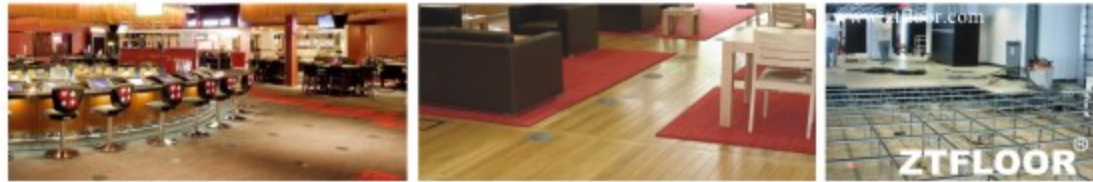

Structure

Woodcore access floor consists of high-density (720Kg/m³) chipboard. Galvanized steel sheet/aluminum foil is bonded to the bottom of the chipboard. HPL or PVC is stuck to the top of the chipboard, four edges are sealed with PVC edging strip.

地板采用高密度阻燃刨花板(720Kg/m³)基材, 表面可粘贴防静电HPL、导电PVC, 底面采用优质镀锌板(或铝皮)封底, 四周采用导电胶条封边。

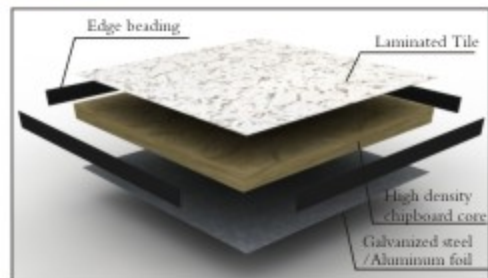
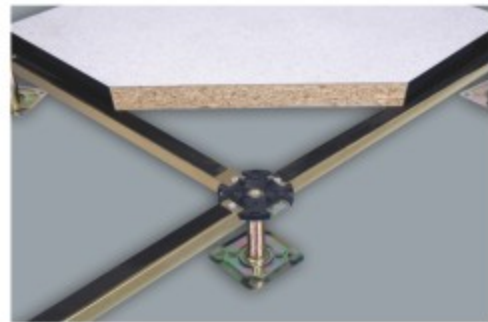

Size

600×600×40mm
600×600×30mm

Feature

- Light weight, small noise when working
- Dimension accuracy with nice interchangeability.
- Strong loading capacity, fire resistance B2 and excellent anti-static properties.
- Good sealing and water-proof.

- 重量轻、噪音小;
- 外形尺寸精确度高, 地板可任意互换;
- 承载能力好, 防火性能达B2级, 防静电性能优;
- 密封性好, 防潮性能强;

Type 型号	Size 尺寸	Concentrated 集中载荷	Impact Load 冲击载荷	Ultimate Load 极限载荷	Uniform Load 均布载荷	Rolling Load 滚动载荷N
International	mm	N	N	N	NM ²	10次 10000次
Light duty 轻型	600 × 600	≥ 2990	670	≥ 8890	≥ 12500	2215 1548
Medium duty 中型	600 × 600	≥ 3596	670	≥ 10799	≥ 19796	2959 2215
Heavy duty 重型	600 × 600	≥ 4498	670	≥ 13494	≥ 23294	3596 2959

WOODCORE ACCESS FLOOR 木质高架活动地板

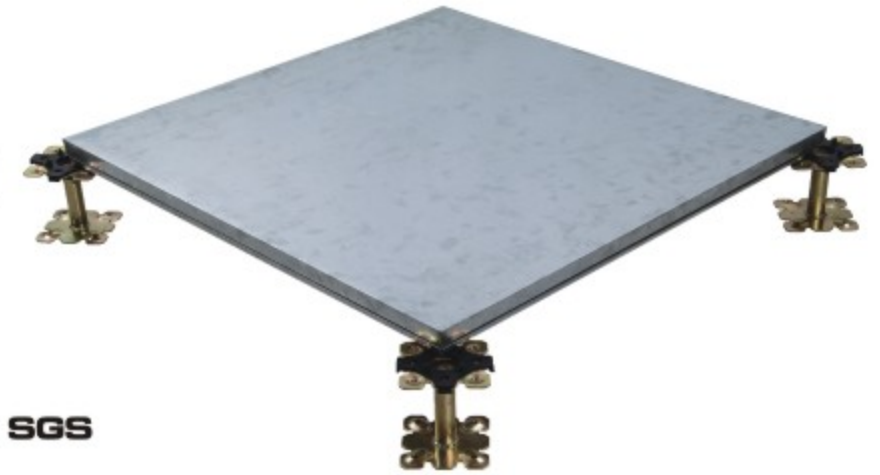

ENCAPSULATED PANEL 多层包边木地板



Structure

Floor panel is encapsulated to provide full steel encasement, steel to be high quality galvanized steel sheet as top and bottom. High density chipboard as the core.

结构: 其材用高密度刨花板, 上、下采用优质镀锌钢板包边, 地板四周镀锌钢板经冲压铆接而成。

Size

600×600×30mm
600×600×25mm

Application

- Woodcore panel is widely used in high-grade rooms, such as banks, telecommunication centers, smart offices and computer rooms.
- This panel is particularly suitable for areas of high humidity.
- High dimension accuracy and environmental proof.

应用:

- 各种防静电要求、承载要求、铺装效果要求高档的场合, 如银行、电信机房、智能化办公室、高档机房。
- 镀锌板包边木地板, 尤其适用于较潮湿的机房环境。
- 外形尺寸精确度高, 绿色环保。

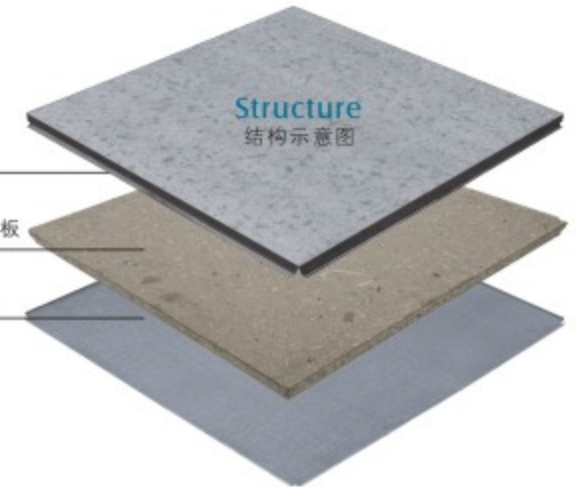

Type 型号	Size 尺寸	Concentrated 集中载荷	Impact Load 冲击载荷	Ultimate Load 极限载荷	Uniform Load 均布载荷	Rolling Load 滚动载荷N
International	mm	N	N	N	NM ²	10次 10000次
Light duty 轻型	600 × 600	≥ 2990	670	≥ 8890	≥ 12500	2215 1548
Medium duty 中型	600 × 600	≥ 3596	670	≥ 10799	≥ 19796	2959 2215

CALCIUM SULPHATE ACCESS FLOOR

硫酸钙高架地板



硫酸钙地板生产线

ENCAPSULATED PANEL 全包硫酸钙地板

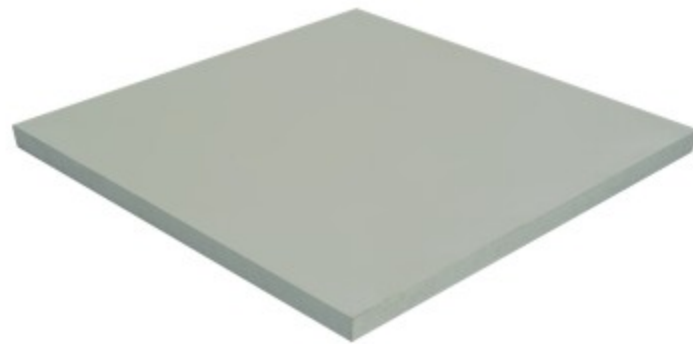

Structure

Encapsulated with high density fiber calcium sulphate core.
结构: 全包硫酸钙地板由上下镀锌钢板和高密度硫酸钙基材构成。

Size

600×600×30mm

Feature

- Full steel encasement and good sealing.
- Constituted by all steel sheet, good loading capacity.
- High dimension accuracy and excellent interchangeability.
- Water-proof, fire-proof, antiseptic and sound insulation.
- Elaborated made and good decorative effect.
- 全包封闭结构、密封性强;
- 承载力、抗冲击性能高;
- 表面平整度、外形尺寸精确度高, 地板可任意互换;
- 阻燃、隔热、隔声、防腐等性能好;
- 外表整齐美观、装饰性强、行走脚感舒适。

Type 型号	Size 尺寸	Concentrated 集中载荷	Impact Load 冲击载荷	Ultimate Load 极限载荷	Uniform Load 均布载荷	Rolling Load 滚动载荷N
International	mm	N	N	N	N/M ²	10次 10000次
Heavy duty 重型	600 × 600	≥ 4498	670	≥ 13494	≥ 23294	3596 2959
Extra Heavy duty 加强型	600 × 600	≥ 5595	670	≥ 16797	≥ 33084	4498 3596

CALCIUM SULPHATE ACCESS FLOOR

硫酸钙高架地板



PVC SEALED PANEL PVC封边

Size

600×600×30mm

Structure

Floor panel is encapsulated to provide full steel encasement, steel to be high quality galvanized steel sheet as top and bottom. High density calcium sulphate as the core.

结构: 其材用高密度硫酸钙基材, 表面采用HPL/PVC贴面, 底面镀锌钢板, 四周黑色PVC封边。

PVC panel

Floor consists of calcium sulphate core. Galvanized steel sheet/aluminum foil is bonded to the bottom. HPL or PVC is stuck to the top, four edges sealed with PVC edging strip.

地板采用高密度硫酸钙基材, 表面可粘贴防静电HPL、导电PVC, 底面采用优质镀锌板(或铝皮)封底, 四周采用导电胶条封边。

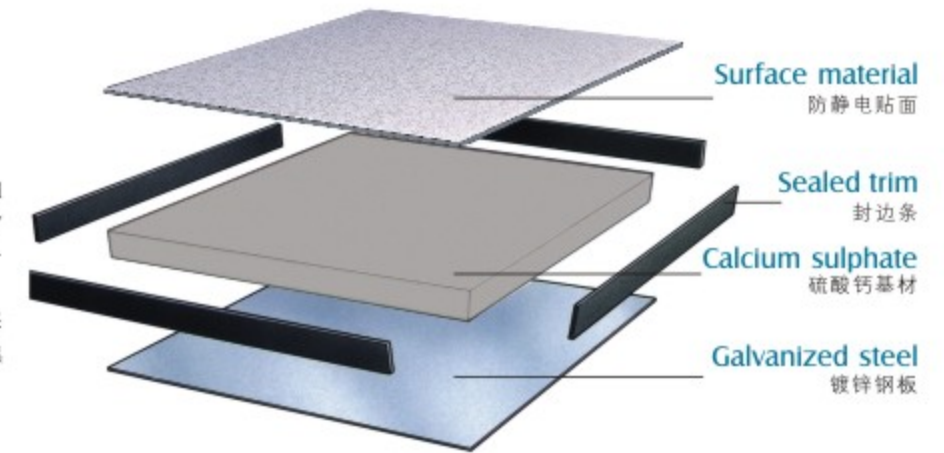

Application

Anti-static calcium sulphate raised floor is widely used in telecommunication room, power station, computer room, factory clean room and other anti-static requiring places.

广泛应用于电信, 电力电子, 微电子, 医学等行业的程控机房, 计算机机房, 电力调度室, 洁净净化厂房等要求防静电场所。

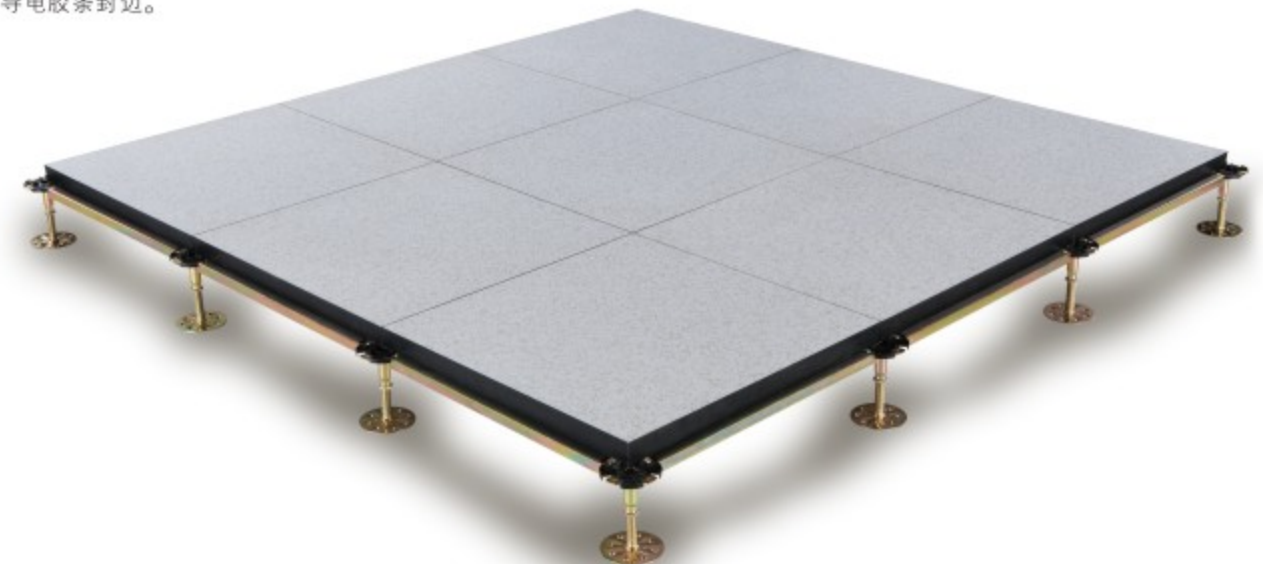

INORGANIC CEMENT FLOOR 无机质水泥地板



INORGANIC CEMENT FLOOR 无机质水泥地板



INORGANIC CEMENT FLOOR 无机质水泥地板

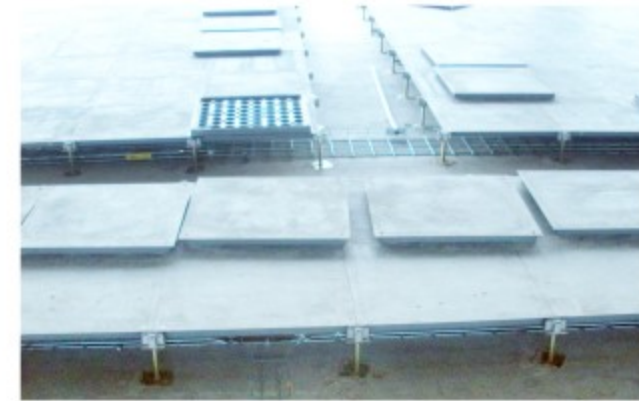

INORGANIC CEMENT FLOOR 无机质水泥地板

Size
500×500×25mm



Structure

结构:
无机质网络地板是由硅酸盐、无机纤维、矿物纤维、石英砂等材料经过高压一次成型的新一代绿色环保网络地板。

该地板无任何挥发性有毒物质及辐射，可以完全被分解，使用年限与楼宇相同。

每块地板自带穿线孔，地板四角镀锌底座支撑，不带横梁系统。

安装后平整度高，无发软的感觉，其表面铺设材料可用强化地板、PVC、方块地毯等。

FRC access floor is made of silicate, inorganic fiber, mineral fiber, quartz sand, etc, once - molded after high pressure.

The panel has no volatile toxic chemicals and radiation, and can be decomposed completely. Its service time is the same as the building.

Each panel has hole for wires, four corners supported by pedestals, with no stringers.

Good flatness and solid feeling. Finishes can be laminate flooring, PVC, carpet, etc.

Type 型号	Size 尺寸	Concentrated 集中载荷	Impact Load 冲击载荷	Ultimate Load 极限载荷	Uniform Load 均布载荷	Rolling Load 滚动载荷N	
International	mm	N	N	N	N/M ²	10次	10000次
Heavy duty 重型	500 × 500 × 25	3000	3000	≥ 9000	≥ 12500	2215	1548
Extra Heavy duty 加强型	500 × 500 × 25	5000	5000	≥ 15000	≥ 28598	4121	3210

Feature

- Full steel encasement and good sealing.
- Constituted by all steel sheet, good loading capacity.
- High dimension accuracy and excellent interchangeability.
- Water-proof, fire-proof, antiseptic and sound insulation.
 - Elaborated made and good decorative effect.
- 全包封闭结构、密封性强;
 - 承载力、抗冲击性能高;
- 表面平整度、外形尺寸精确度高，地板可任意互换;
 - 阻燃、隔热、隔声、防腐等性能好;
- 外表整齐美观、装饰性强、行走脚感舒适。

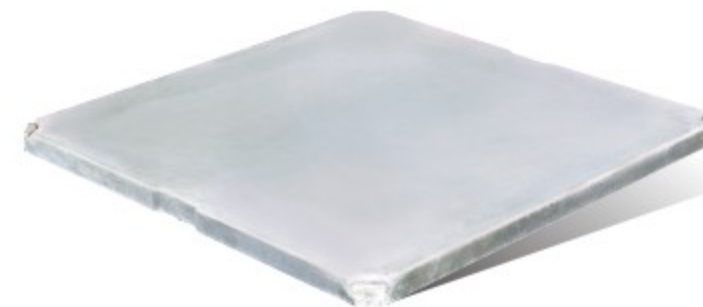

ALUMINUM ACCESS FLOOR

铝合金高架地板

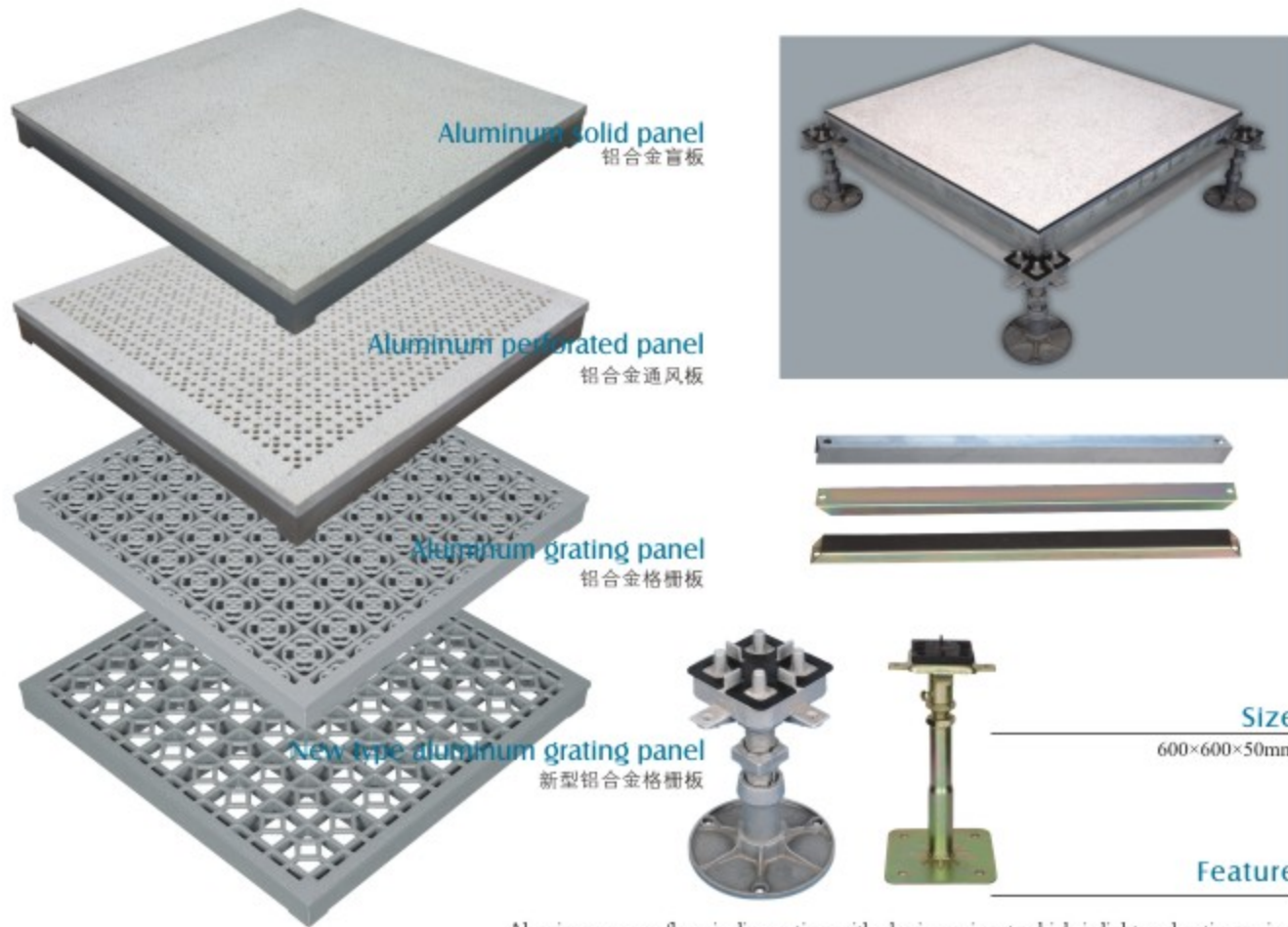

Size

600×600×50mm

Feature

Aluminum access floor is die-casting with aluminum ingot which is light and anticorrosion. Aluminum access floor is widely used in the Aerospace Center, Military Command Headquarter, Data Center and Clean Room.

压铸铝合金地板质地轻巧，耐腐蚀。广泛的应用于航天中心，军事指挥中心，数据中心和洁净室。

Type	Size	Concentrated	Impact Load	Ultimate Load	Uniform Load	Rolling Load	
型号	尺寸	集中载荷	冲击载荷	极限载荷	均布载荷	滚动载荷N	
International	Material	mm	N	N	N/M ²	10次 10000次	
A1000	ACD-12	600 × 600	≥4498	670	≥13494	≥23294	3596 2959
A1500	ACD-12	600 × 600	≥6693	670	≥20090	≥42581	5595 4498

UNDER STRUCTURE

支架系统

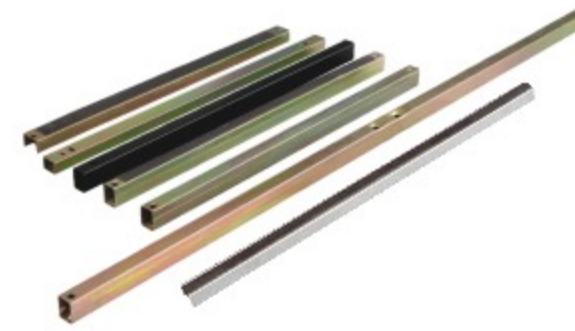

Stringers 横梁

Stringers provide lateral resistance to heavy rolling loads & seismic loading.

横梁可提升滚动载荷和抗震载荷。



Heavy pedestal 重型支架



C01 C02 C03 C04

Cross head pedestal 铝头/铁头支架



F06 F01 F02 F05

Flat head pedestal 平头支架



W03 W05 W07 W09

Round head pedestal 圆头支架

Finished flooring height (FFH) from 80mm to 2,000mm is available, with high loading strength.

"朝晖"牌地板和"ZTFLOOR"牌地板支架高度可以定做，完成高度80mm到2,000mm。

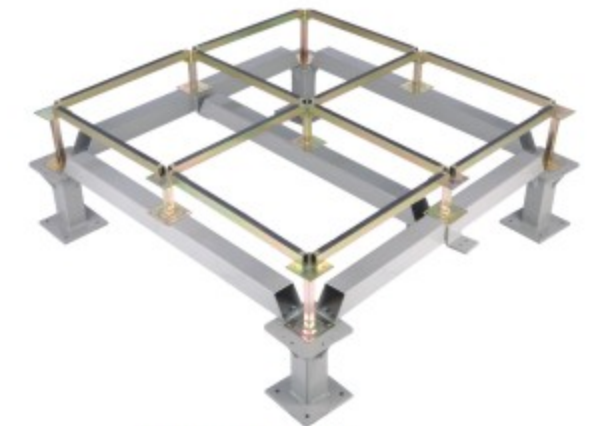

Seismic pedestal 防震支架系统



Ramp pedestal 斜坡支架 Pedestal bracing 斜支撑



规格:Φ38 规格:Φ32

Bracing clamp 抱箍

AIR FLOW SYSTEM

通风板系列

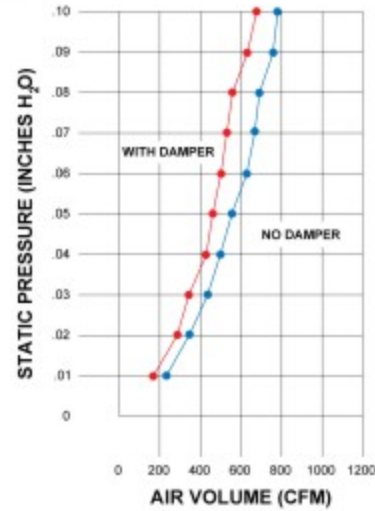
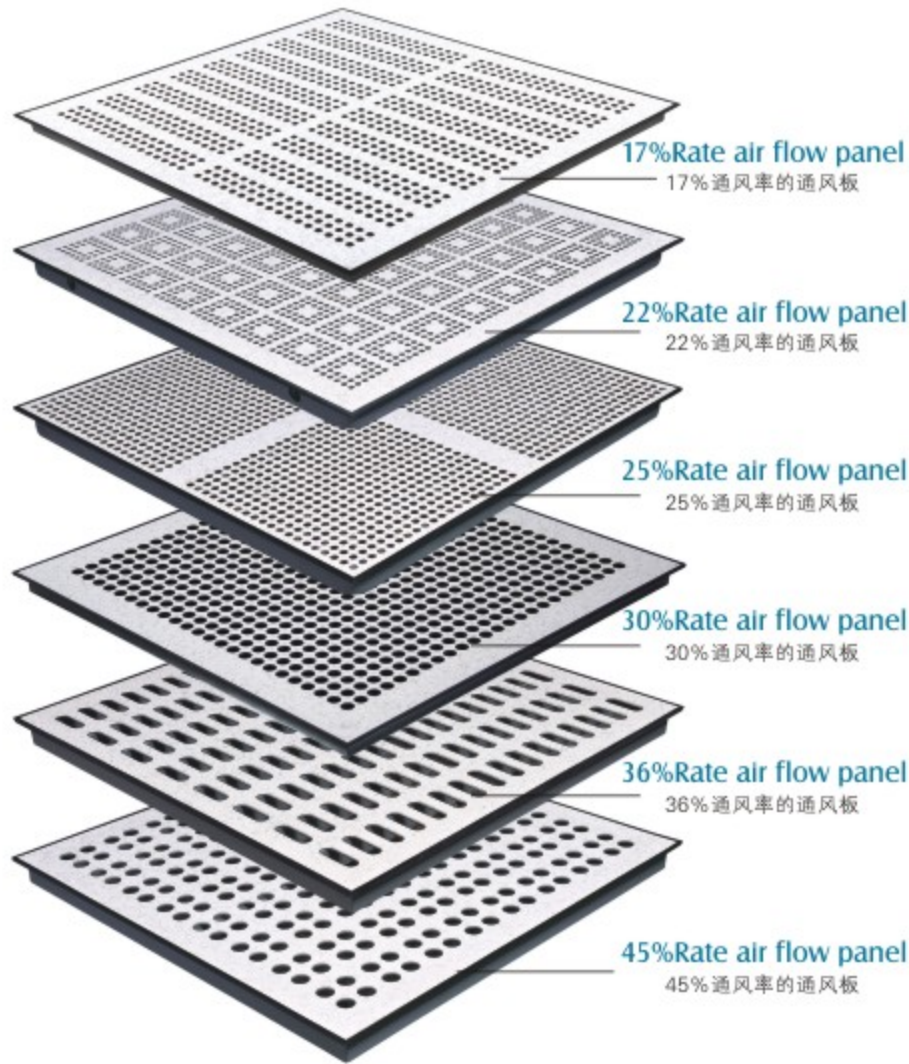

Size

600 × 600 × 35mm
610 × 610 × 35mm

Feature

Provide superior cooling for managing heat loads in mission critical facilities. Available with top surface adjustable dampers. The steel perforated panels are same size and finish as the solid panel, so they are available with High Pressure Laminates, Vinyl and rubber floor coverings interchangeable with woodcore panel/calcium sulphate panel.

特点：提供通风功能，可与风量调节器一起使用。以上通风板可以和贴面地板、木地板、硫酸钙地板配套使用。

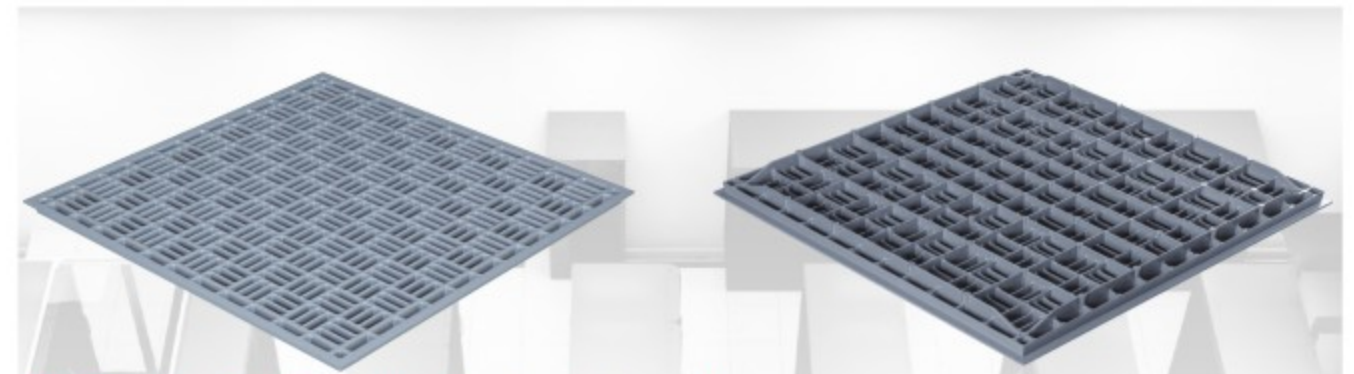

56% Opening Rate Die-casting aluminum grate panel (interchangeable with steel panel)

56%通风率压铸铝格栅板（可与钢板一起使用）

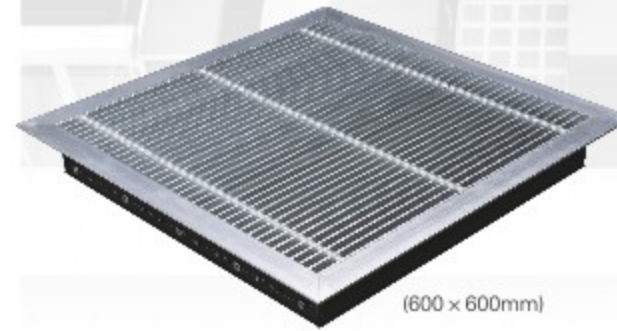

Aluminum Grille

铝风口



Air Diffuser

散流器



Sliding Damper

平移式调节器

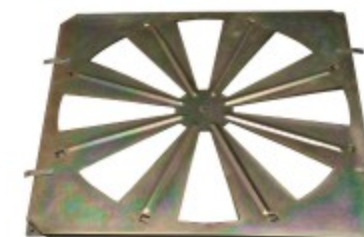

Round Damper

旋转式调节器



Opposite Open Damper

(for aluminum grate panel and air grille)
对开式调节器

ZTFLOOR also promote access floor under floor air plenum system. For more details, please contact company sales.

中天公司另生产高架地板下通风系统，请向公司业务经理索取相关资料。

AIR FLOW SYSTEM

通风系统

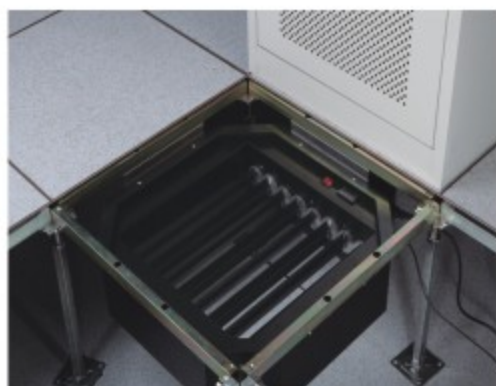

温控变风量风阀 Temperature Control VAV damper

ZTFLOOR underfloor temperature control VAV damper is used to provide sufficient air to accommodate the peak energy demands of the rack, resulting in wasted bypass air and over-cooling during all less than peak conditions. The damper measures the incoming air temperatures at the face of the rack and adjusts the VAV damper to control the air flow and ensure that the temperature at the face of the rack is never above the maximum allowable set point provided by the user.

中天公司的温控变风量风阀广泛用于数据中心，使用过程中，温控风阀安装于相邻的两排机柜中间，通过电子传感器来侦测机柜柜体内部的温度变化，并把检测数据传送到电脑，电脑会对比此结果与程序提前设定的温度温度差异，由电脑自动调节风阀开闭角度的大小来调整风量的强度。由此控制机柜内部温度恒定，进而达到节约能源消耗的目的。

温控变风量风扇 Temperature Control Fan System

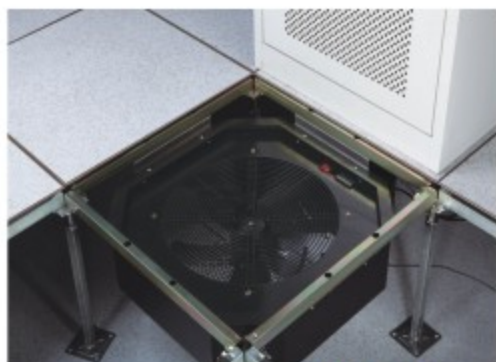

Fan Unit 单风扇

ZTFLOOR Air boosted Power Fan Unit is designed to provide a blast of cooling through an individual directional airflow panel. The temperature controlled fan units are available quad fan models. The fan has multiple control options to automatically turn on when conditions require additional cooling. This powerful solution is ideal for solving the toughest hot spots in a data center.

风扇设计原理如下，通过调整一个或四个相对独立的风扇转速，从而为机房提供有效冷却方式。工作过程中，当系统的温度传感器检测到当前温度超过系统要求的范围时，系统自动打开并调节温控风扇旋转速度。从而保证温度保持恒定。这也是中天公司为解决数据中心温度要求而提供的一种高效的解决方案。

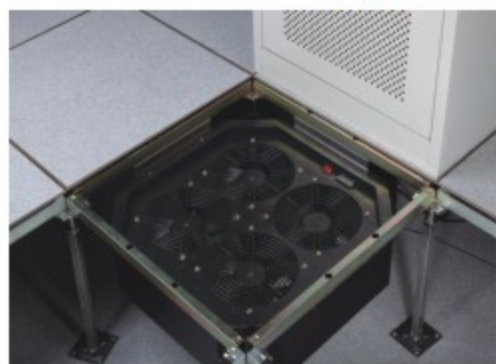

Four-Fan Unit 4风扇

性能特点 Performance Characteristics

- Zero maintenance
- Installation can be carried out by IT staff
- Multiple control options for both models available
 - VN - client sensor network
- High Precision, Quick Response Temperature Measurement
 - User programmable set point
- Viewable Peak Temp for walkthrough check of each rack
- Infinitely variable fan speed from 0-100% for precise airflow control
 - Easily installs into either 24" or 60cm raised floor systems
 - 容易安装，0 维护
 - 多种控制方式可以选择
 - 电子传感侦测系统
 - 温度控制精确高效
 - 自由设定温度控制点
 - 单个排机柜温度可自由设定
 - 风量可由0 到100% 自由控制
- 配套600 × 600或24" × 24" 地板系统使用

Product Overview 产品概述

Directional Perforated Access Floor Panels to angle the air toward the equipment achieving a 93% Total Air Capture (TAC) rate by a standard server rack. This means 93% of the airflow delivered through the airflow panel is entering the face of the server rack, providing more capacity and energy efficiency of any other perforated airflow panel on the market.

- 20% open area delivers 640m³/h at 25 Pa when installed without a damper.
- Directional air flow achieves a 93% total air capture.
- Cools over 8kW per rack.
- Over 40% annual fan energy savings.
- Reduces capital expenditures on cooling infrastructure by 40%.
- Available in 3 concentrated load ratings 800, 1000 and 1250 lbs.
- Easily integrates into an existing 24" raised floor system

中天的导向型通风板定向气流角度直接送风给服务器机柜，不同于其他送风格栅，直接送风角度对准服务器机柜，极大地减少了旁通风量。和标准42U机柜一一配对使用。提供定向送风，设计坚固，提高能效。



20% Rate Directional Perforated Access Floor Panels

20% 通风率导向型通风板

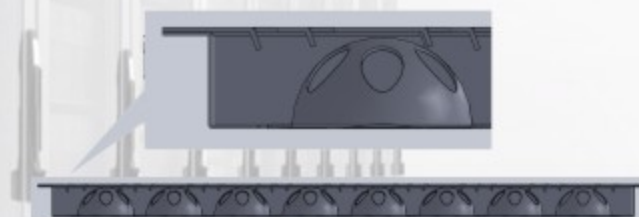

Structure 解剖图

68% Directional Grate Panel

68% 导向型 格栅通风板

Meets CIBCA and BS EN 12825 standards.
符合CIBCA和BS EN 12825标准

Comes with a split leaved damper so you can adjust the volume of air
带可调叶片风阀可调节风量

Extremely durable, galvanized powder coat finish to prevent corrosion.
极其耐用，表面镀锌处理，耐腐蚀

The only directional airflow panel in the world made of cast aluminum.
全球唯一压铸铝制通风板

气流测试 AirFlow Measurement

Static Pressure 静压	CFM
0.031 H ₂ O 7.68Pa	~800
0.038 H ₂ O 9.37Pa	~900
0.044 H ₂ O 11.0Pa	~950

Zone 3
Zone 2 76°
Zone 1

高架地板配件



"ZT FLOOR" presents an extensive choices of accessories, including electrical boxes, grommets, panel lifters and air diffuser and so on.

"朝晖"牌地板提供配件, 如走线盒、电插座、支架胶水等。



Round brush grommet 圆形刷子走线盒



Surface brush grommet 方形刷子走线盒



Split integral grommet 半开型走线盒

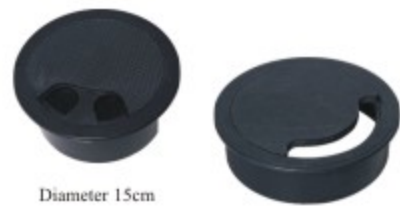

Diameter 15cm

Diameter 19.5cm

Round Grommet 圆形走线盒



Square Grommet 方形走线盒



Integral grommet 长方形走线盒



Single/Double cup lifter 单(双)吸盘



Outlet box B 地插座B



Outlet box C 地插座C

Covering Material
贴面材料

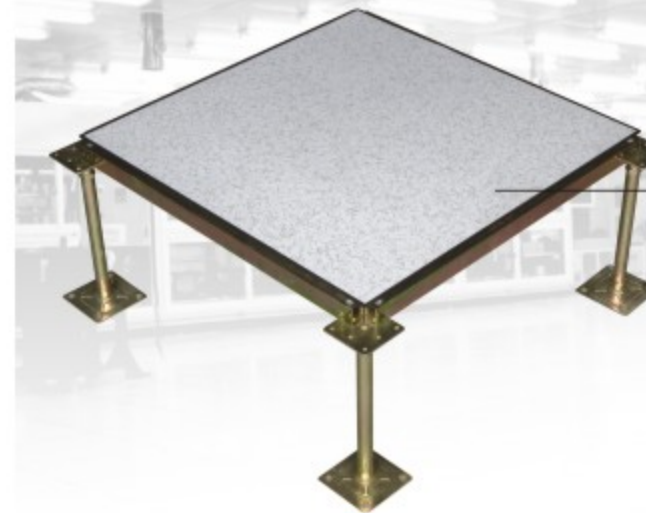

Variety of covering materials are available
更多贴面可供选择

A Comprehensive selection of ZTFLOOR covering materials are available including more colors of HPL, PVC and other interior finishes, to satisfy customer's different requirements. Please contact with us if you want other covering material which is not listed below.

为增强功能性和美观性能, 中天朝晖牌抗静电活动地板提供更多颜色的防火板、PVC或其他贴面材料。

High Pressure Laminate(HPL) 防火板

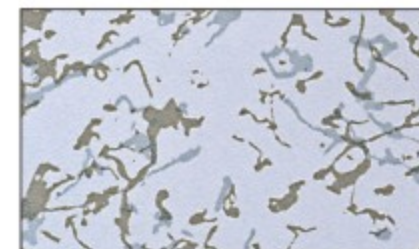

8192

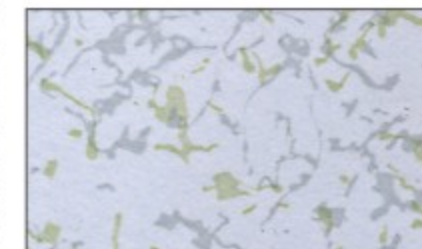

8193



8194

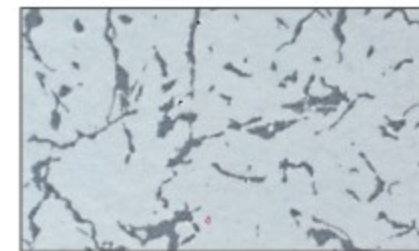

8191



8132



8120

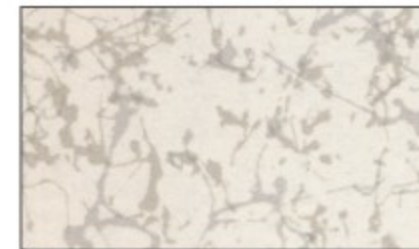

8194-1

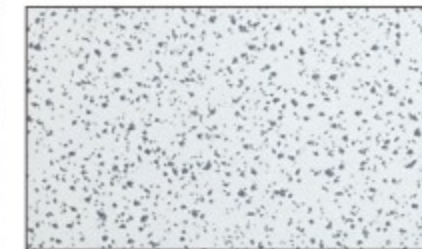

8144

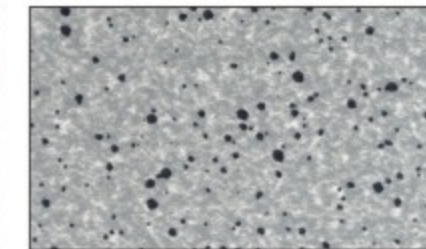

8138



8137

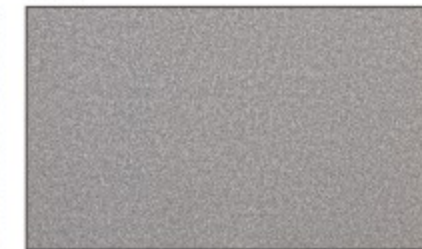

8119

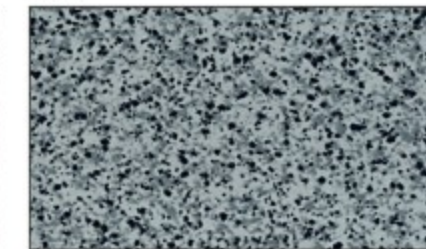

8117

Covering Material

贴面材料

Conductive PVC tile 导电PVC地砖(10¹-10⁶ohms)

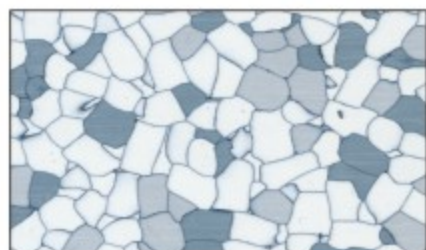

ZT-1101

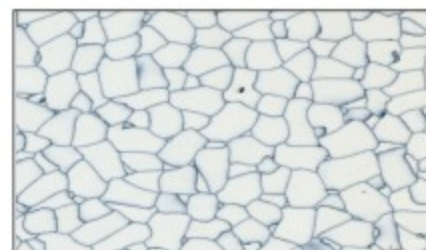

ZT-1103

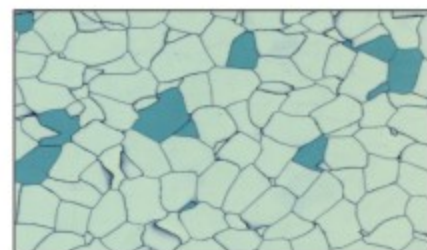

ZT-02

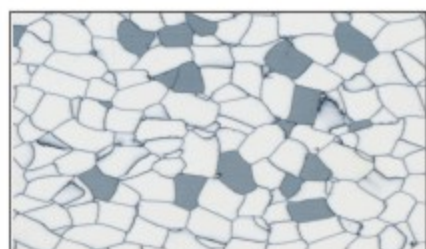

ZT-04

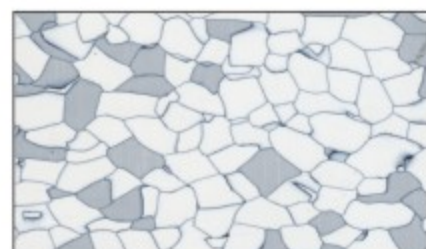

ZT-909



ZT-9022

Ceramic tile 陶瓷

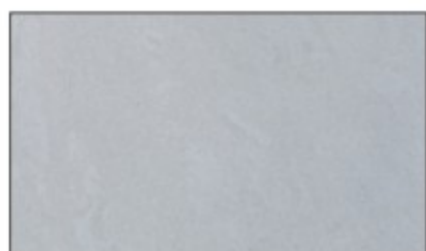

2058

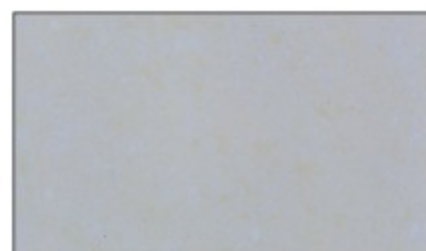

2060

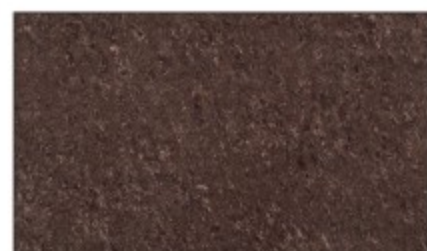

2070

Homogeneous vinyl 弹性透心面材



2058



2062

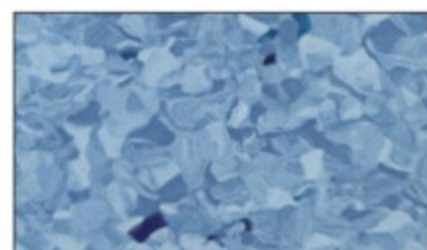

2070

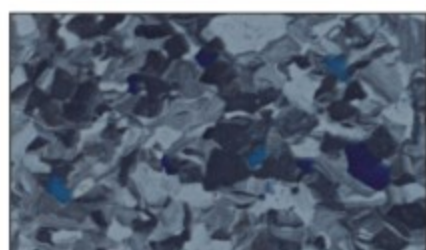

2051

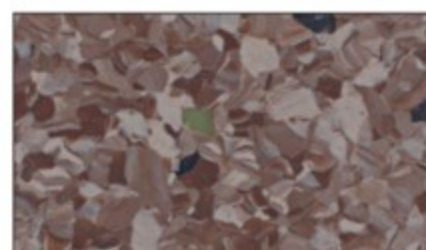

2060



2066

Covering Material

贴面材料

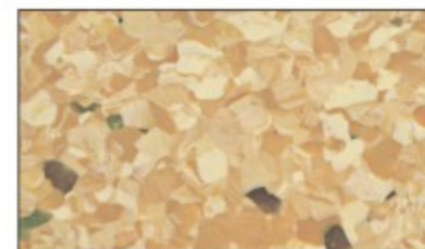

2073



2072

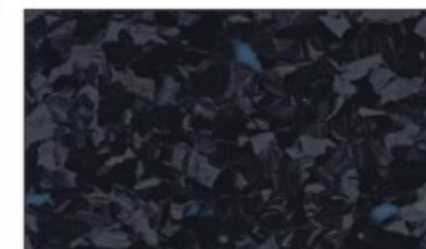

2050

Linoleum 环保亚麻



3881

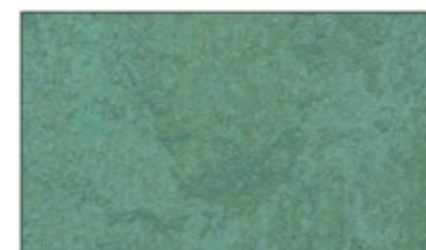

3882

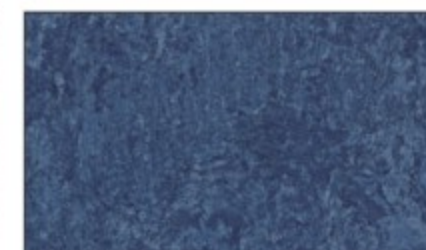

3856

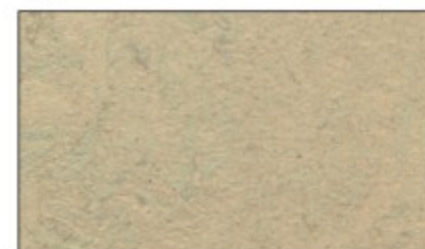

3858

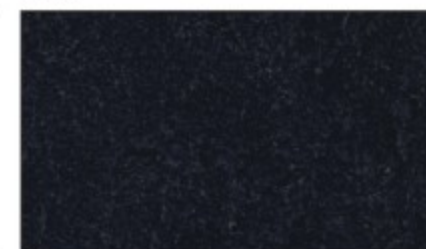

3872

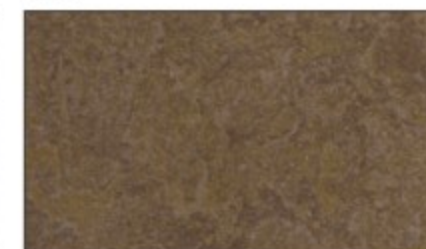

3876

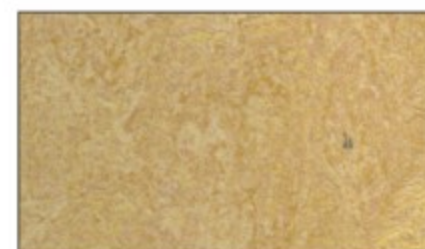

3846

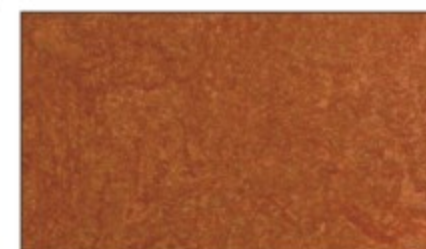

3825

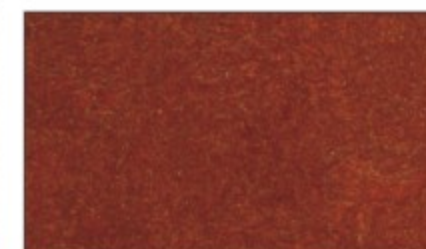

3870

Granite 大理石



蒋田锈



黑冰花



G655



www.ztfloor.com

ZTFLOOR®



Intertek SGS

Project reference 工程案例



盐城金融城
Yancheng Financial City
地点(Place): 盐城 Yancheng
面积(Area): 145700m²
地板类型(Panel Type): OA网络地板



苏州尼盛广场
Suzhou Nisheng Building
地点(Place): 苏州 Suzhou
面积(Area): 38000m²
地板类型(Panel Type): OA网络地板



深圳威盛大厦
Shenzhen Weisheng Building
地点(Place): 深圳 Shenzhen
面积(Area): 30000m²
地板类型(Panel Type): OA网络地板



上海博世研发中心大楼
Bosch Shanghai Research Center
地点(Place): 上海 Shanghai
面积(Area): 27000m²
地板类型(Panel Type): OA网络地板



上海长丰大厦
Shanghai Changfeng Building
地点(Place): 上海 Shanghai
面积(Area): 22000m²
地板类型(Panel Type): OA网络地板



上海新桥商务广场
Shanghai Xinqiao Business Center
地点(Place): 上海 Shanghai
面积(Area): 22000m²
地板类型(Panel Type): OA网络地板



南京七星凌
Nanjing Qixingjun
地点(Place): 南京 Nanjing
面积(Area): 15000m²
地板类型(Panel Type): OA网络地板



南昌银行金融服务中心
Nanchang Bank Financial Services Centre
地点(Place): 南昌 Nanchang
面积(Area): 20000m²
地板类型(Panel Type): 硫酸钙网络地板



南昌欧菲光科技
Nanchang Oufei Guang Technology
地点(Place): 南昌 Nanchang
面积(Area): 9500m²
地板类型(Panel Type): 铝合金地板



北京电信通信指挥楼
China Telecom (Beijing) Office Building
地点(Place): 北京 Beijing
面积(Area): 15000m²
地板类型(Panel Type): HPL抗静电地板



南昌绿地新都会
Nanchang Greenland Center
地点(Place): 南昌 Nanchang
面积(Area): 20000m²
地板类型(Panel Type): 新型线槽网络地板



上海巴克莱银行
Barclays Bank Shanghai
地点(Place): 上海 Shanghai
面积(Area): 25000m²
地板类型(Panel Type): OA网络地板



苏州国信大厦
Suzhou Guoxing Building
地点(Place): 苏州 Suzhou
面积(Area): 15000m²
地板类型(Panel Type): OA网络地板



成都棕榈泉国际中心
Chengdu Palm Springs International Center
地点(Place): 成都 Chengdu
面积(Area): 50000m²
地板类型(Panel Type): OA网络地板



上海展想电子
Shanghai Zhangxiang Electronic Co., Ltd
地点(Place): 上海 Shanghai
面积(Area): 40000m²
地板类型(Panel Type): OA网络地板

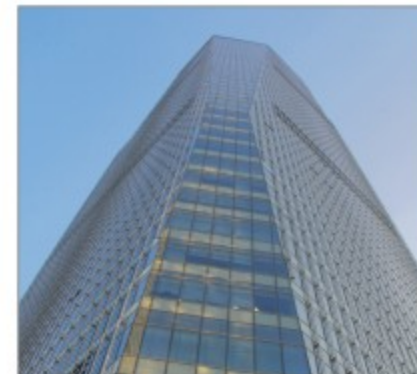

上海惠普工厂
HP Shanghai Factory
地点(Place): 上海 Shanghai
面积(Area): 12000m²
地板类型(Panel Type): OA网络地板



上海杜邦办公大楼
DuPont Shanghai Office Building
地点(Place): 上海 Shanghai
面积(Area): 15000m²
地板类型(Panel Type): OA网络地板

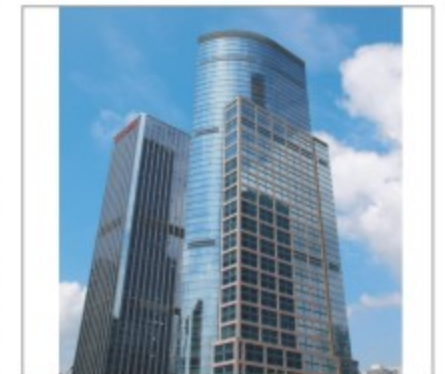

上海阿斯利康办公大楼
AstraZeneca (Shanghai) Office Building
地点(Place): 上海 Shanghai
面积(Area): 10000m²
地板类型(Panel Type): OA网络地板



www.ztfloor.com

ZTFLOOR®



Intertek SGS

Project reference 工程案例



盐城金融城
Yancheng Financial City
地点(Place): 盐城 Yancheng
面积(Area): 145700m²
地板类型(Panel Type): OA网络地板



苏州尼盛广场
Suzhou Nisheng Building
地点(Place): 苏州 Suzhou
面积(Area): 38000m²
地板类型(Panel Type): OA网络地板



深圳威盛大厦
Shenzhen Weisheng Building
地点(Place): 深圳 Shenzhen
面积(Area): 30000m²
地板类型(Panel Type): OA网络地板



上海博世研发中心大楼
Bosch Shanghai Research Center
地点(Place): 上海 Shanghai
面积(Area): 27000m²
地板类型(Panel Type): OA网络地板



上海长丰大厦
Shanghai Changfeng Building
地点(Place): 上海 Shanghai
面积(Area): 22000m²
地板类型(Panel Type): OA网络地板



上海新桥商务广场
Shanghai Xinqiao Business Center
地点(Place): 上海 Shanghai
面积(Area): 22000m²
地板类型(Panel Type): OA网络地板



南京七星楼
Nanjing Qixingjun
地点(Place): 南京 Nanjing
面积(Area): 15000m²
地板类型(Panel Type): OA网络地板



南昌银行金融服务中心
Nanchang Bank Financial Services Centre
地点(Place): 南昌 Nanchang
面积(Area): 20000m²
地板类型(Panel Type): 硫酸钙网络地板



南昌欧菲光科技
Nanchang Oufeiguang Technology
地点(Place): 南昌 Nanchang
面积(Area): 9500m²
地板类型(Panel Type): 铝合金地板



北京电信通信指挥楼
China Telecom (Beijing) Office Building
地点(Place): 北京 Beijing
面积(Area): 15000m²
地板类型(Panel Type): HPL抗静电地板



南昌绿地新都会
Nanchang Greenland Center
地点(Place): 南昌 Nanchang
面积(Area): 20000m²
地板类型(Panel Type): 新型线槽网络地板



上海巴克莱银行
Barclays Bank Shanghai
地点(Place): 上海 Shanghai
面积(Area): 25000m²
地板类型(Panel Type): OA网络地板



苏州国信大厦
Suzhou Guoxing Building
地点(Place): 苏州 Suzhou
面积(Area): 15000m²
地板类型(Panel Type): OA网络地板



成都棕榈泉国际中心
Chengdu Palm Springs International Center
地点(Place): 成都 Chengdu
面积(Area): 50000m²
地板类型(Panel Type): OA网络地板



上海展想电子
Shanghai Zhangxiang Electronic Co., Ltd
地点(Place): 上海 Shanghai
面积(Area): 40000m²
地板类型(Panel Type): OA网络地板



上海惠普工厂
HP Shanghai Factory
地点(Place): 上海 Shanghai
面积(Area): 12000m²
地板类型(Panel Type): OA网络地板



上海杜邦办公大楼
DuPont Shanghai Office Building
地点(Place): 上海 Shanghai
面积(Area): 15000m²
地板类型(Panel Type): OA网络地板



上海阿斯利康办公大楼
AstraZeneca (Shanghai) Office Building
地点(Place): 上海 Shanghai
面积(Area): 10000m²
地板类型(Panel Type): OA网络地板